



### 1. Overview:

AW-EXD103 explosion-proof smoke and heat combined detector is performance in line with GB3836-2000 series of standards, inspected by the state designated inspection units, and acquired explosion-proof certificate. Smoke and heat combined detector is available in 1 and 2 Zone hazardous locations which include Class II A, B, C class T1 ~ T6 temperature group explosive gas environment.

AW-EXD103 explosion-proof smoke and heat combined detector is a kind of non-coding switching detector (relay output), can be used with any domestic and foreign manufacturers of fire alarm control panel.

AW-EXD103 explosion-proof point-type composite heat detectors sense smoke Not only has the general performance of scatter-type photoelectric smoke detect, but also fixed and differential fixed temperature performance of heat detectors.

When smog concentrations exceed the set threshold or when the temperature reached the set value, the detector indicator is lit, warning letter is issued by controller.

### 2. The Main Technical Parameters

1. Explosion-proof mark: Exd ib II CT6
2. Operating voltage: DC24V  $\pm$  3V (polarity)
3. Monitor Current:  $\leq$ 60 $\mu$ A
4. Alarm current:  $\leq$ 30mA
5. Alarm output form:  
normally open and closed  
a pairs of dry contact output
6. Response threshold: 0.10dB / m ~ 0.27 dB / m
7. Alarm reset: power outages (10s Min,

DC2.5V Max)

8. Power Time:  $\leq$ 10S
9. The highest wind speed: 7.6m / s (1500fpm)
10. Alarm confirmation light: red, strobe when the inspection, alarm Always
11. protection area: When space height is 6m ~ 12m, a protected area of the detector, the general protection of the site in terms of 80m<sup>2</sup>. When space height is 6m or less, to protect an area of 60m<sup>2</sup>.
12. Use of the environment:  
Temperature: -10  $^{\circ}$ C ~ + 50  $^{\circ}$ C  
Relative humidity:  $\leq$ 95% non-condensing  
Atmospheric pressure: 80kPa ~ 110kPa
13. The outlet thread: G20
14. Weight: 1.2kg

### 3. Contour Map

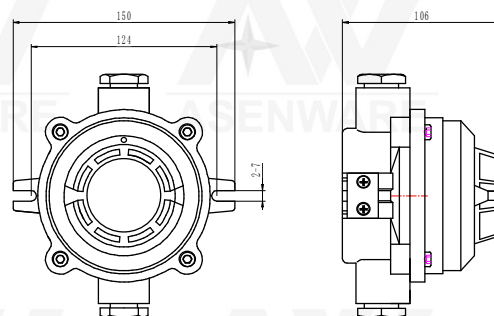

### 4. Installation and Wiring

1. Installation: according to the site with the M6 screws through the mounting foot detector probe explosion-proof housing is fixed to the ceiling.
2. Wiring :( see below)

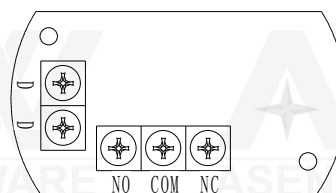

DD: DC24V (non polar); NO: normally open contact; COM: Common; NC:

normally closed contact

**5. Notes**

1. Strictly prohibited in flammable and explosive places live demolition.
2. Not to damage the surface explosion during installation, and keep it clean. Surface explosion fastening screws should be tightened evenly, do not pay attention to proof surface foreign material.
3. Long-term use on a regular basis to detect performance of the detector is intact, such as failure or damage to the special Industry personnel.

AW-EXD103 type

Explosion-point type composite heat detectors sense smoke  
Installation using SHEET

